

The **SPIRIT** collection

SEAFIRE

How to use your watch

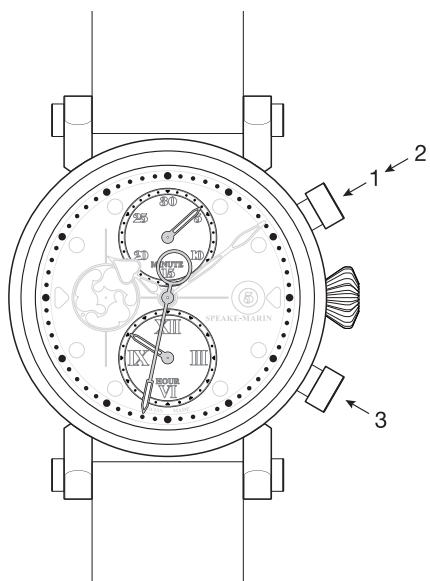

CHRONOGRAPH OPERATION

1. Start

Press push-button 1 to activate the seconds hand on the chronograph. If the length of the activity time exceeds 60 seconds, the additional time is displayed on the minute counter.

2. Stop

Press push-button 1 for the second time to stop the chronograph and see the elapsed time (in seconds, minutes and hours). By again pressing push-button 1, the time restarts immediately. You can therefore, measure several consecutive periods.

3. Reset

After having stopped the chronograph by pressing push-button 1, press push-button 3 to reset all the other counters.

The watch is now ready to count a new period again.

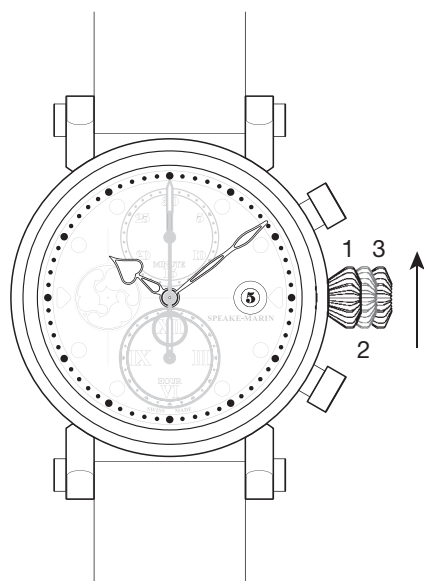

WATCH SETTING

THREE-position crown

1. Neutral and winding position

Allows the user to manually wind their watch by turning the crown upwards.

2. Quick setting position for the date

Allows the user to change the date by simply turning the crown downwards.

3. Time setting position

Allows the user to set the time by turning the crown and turning the hands to the right time.



SPEAKE-MARIN

CAUTION

The owner of the watch must under no circumstances, use the system quick change date system (crown in position 2) between 20h00 and 2h00.

If the user does not know if the watch is in the AM or the PM mode, they should set the hands so that the hour displayed is 2h00 (crown in position 3), and once the date is changed, they can modify it without risk of damaging the movement or altering its accuracy.

When you set the time during an afternoon, remember to do this after 12h00 to be in the right AM/PM sequence.

After having carried out this operation, put the crown back in position 1, turn it downwards once and check that it turns freely.

Every time you manipulate the crown, change the time or the date, remember to return the crown to position 1.

WARNING

Your watch is guaranteed water-resistant to 3 bars (30 m) provided the crown is returned to position 1.